

CLOU COMPACT PELLET

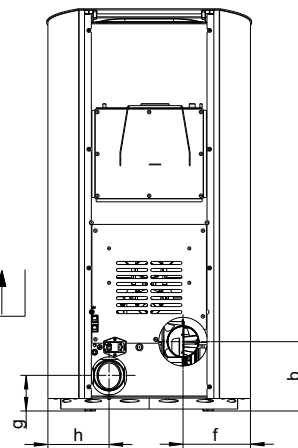

AUSTROFLAMM

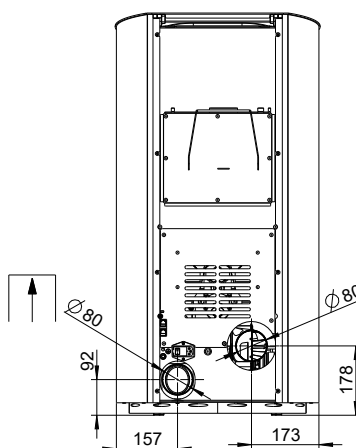
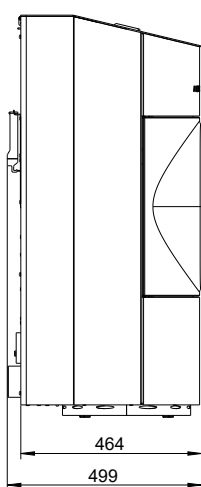
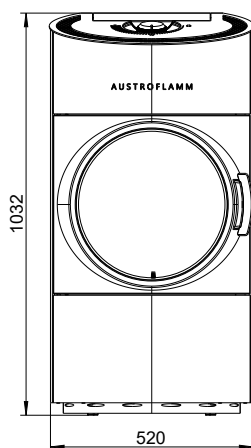
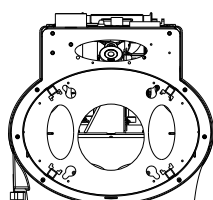
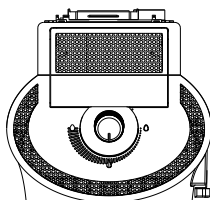

Dimensions and weight

Height [mm]	1033
Width [mm]	520
Depth [mm]	499
Combustion chamber width [mm]	322
Combustion chamber height [mm]	458
Combustion chamber depth [mm]	153
Flue pipe outlet, diameter [mm]	80
Outside air connection diameter [Ø mm]	80
Weight, basic appliance [kg]	127
Weight Xtra [kg]	-
Total weight inc. steel case (STM) [kg]	127
Total weight inc. ceramic case (KGM) [kg]	-
Total weight inc. soapstone case (SPM) [kg]	-
b: Height of flue pipe connection, centre rear (as per diagram) [mm]	178
f: Flue pipe connection from right (as per diagram) [mm]	173
g: Height of external air connection, centre (as per diagram) [mm]	92
h: External air connection from left (as per diagram) [mm]	157

Output

Nominal heat efficiency [kW]	6.0
Minimum heat output [kW]	2.1
Maximum heat output [kW]	6.0
Minimum room heating capacity [m³]	65
Maximum room heating capacity [m³]	165
Pellet hopper capacity [kg/l]	26 / 40
Minimum fuel throughput [kg/h]	0.5
Maximum fuel throughput [kg/h]	1.4
Burning time, minimum [h]	18
Burning time, maximum [h]	52
Power connection [V/Hz]	230 / 50

Equipment

Room temperature sensor	standard
Weekly timer	Accessories
Automatic drop grate	-
Ash removal	Riddling grate
Balanced flue - DiBt (German Institute for Structural Engineering)	Yes
WLAN module	Accessories
Remote control	-
Air distribution module	-

Data for the chimney sweep

Exhaust gas mass flow [g/s]	5.3
Flue gas temperature [°C]	214
Minimum delivery pressure at nominal heat output [Pa]	12
Minimum delivery pressure for chimney calculation [Pa]	3