

PERCY



AUSTROFLAMM



www.austroflamm.com

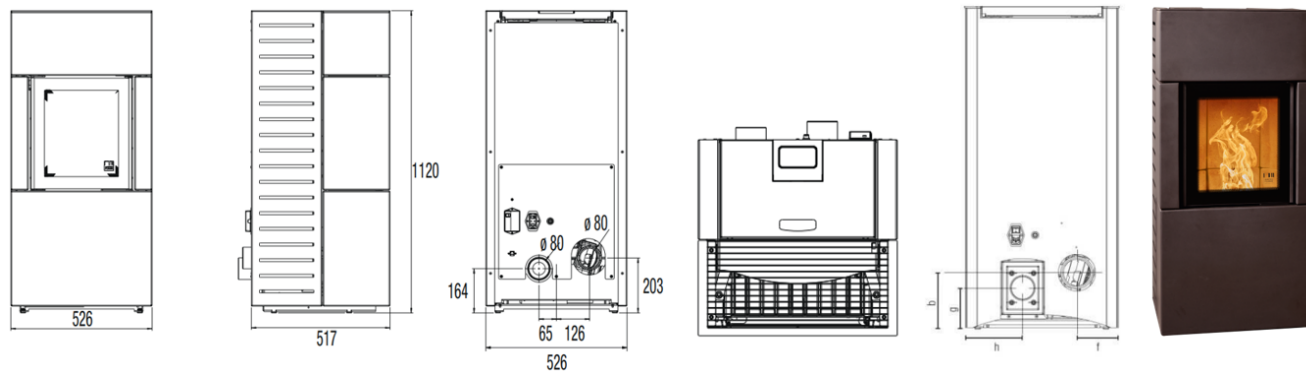

DIMENSIONS AND WEIGHTS

Height x width x depth [mm]	1120 x 526 x 517
Flue pipe outlet, diameter [mm]	80
Outside air connection [Ø mm]	80
Weight [kg]	181
b: Connection height with flue pipe rear [mm]	203
f: Flue pipe connection from right [mm]	137
g: Connection height, outside air [mm]	164
h: Outside air connection from left [mm]	198
Firebox h x w x d [mm]	
Safety distances to combustible materials front / side / rear [mm]	800 / 100 / 100

OUTPUT

Nominal heat efficiency [kW] as per EN 14785	8.0
Min. / max. heat output [kW]	2.4-8.6
Min. / max. space heating capacity [m³]	114-305
Pellet hopper [kg/l]	≈ 25/39
Min. / max. fuel consumption [kg/h]	0.6-2.10
Min. / max. burning time [h]	12-42
Power connection [V/Hz]	230/50
Firebox h x w x d [mm]	
Safety distances to combustible materials front / side / rear [mm]	800 / 100 / 100

FITTINGS

Room thermostat	o
(Weekly) timer	o
Automatic grate	o
Balanced flue	o
WLAN	Z
Remote control	o
Air distribution module	-

DATA FOR THE CHIMNEY SWEEP

Flue gas mass flow [g/s] closed	6.13
Flue gas temperature [°C] closed	208
Minimum delivery pressure at nominal heat output [Pa] closed	12
Minimum delivery pressure for chimney calculation [Pa]	3